

PIT TYPES	
TYPE "A"	AS SHOWN.
TYPE "B"	AS SHOWN, BUT LINTEL LENGTH = 3300.
TYPE "C" (SAG)	LINTEL LENGTH = 3300. GRATE CENTRALLY POSITIONED WITH ENTRIES EITHER SIDE GUTTER DEFLECTORS NOT REQUIRED.

GENERAL NOTES:

1. REFER PROJECT DRAWINGS FOR ACTUAL PIPE LOCATION. ARRANGMENTS SHOWN IN THIS DRAWING ARE DIAGRAMMATIC ONLY.
2. USE N25 CONCRETE TO AS 1379 AND AS3600 FOR ANY PATCHING USE MORTAR MIXED WITH 'LOKRETE' OR SIMILAR.
3. FIBRECRETE MAY BE USED HOWEVER IF USED WITHOUT SEPARATE WALL REINFORCEMENT THEN ENGINEERING OF WALL THICKNESS IS REQUIRED.
4. ALTERNATIVE - GATIC PROPRIETARY OR APPROVED EQUIVALENT FRAMES GRATES AND COVERS MAY BE USED. IF USED, SHALL BE OF APPROPRIATE LOADING CLASS FOR THEIR SITUATION AND INSTALLED IN ACCORDANCE WITH MANUFACTURERS INSTRUCTIONS.
5. ALL STEELWORK TO BE CLEANED AFTER FABRICATION & HOT DIPPED GALVANISED.
6. ALL GRATES LOCATED IN THE ROADWAY OR TRAFFIC WAY ARE TO BE BICYCLE SAFE.
7. FACE BAR AND STEP IRONS ARE TO BE HOT DIPPED GALVANISED.
8. PROVIDE STABILISED BACKFILL ADJACENT TO ALL DRAINAGE STRUCTURES IN ACCORDANCE WITH LITCHFIELD COUNCIL'S STANDARD.

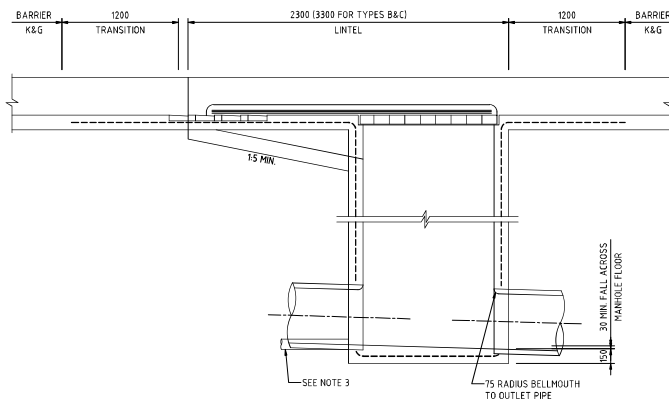

SECTION A-A

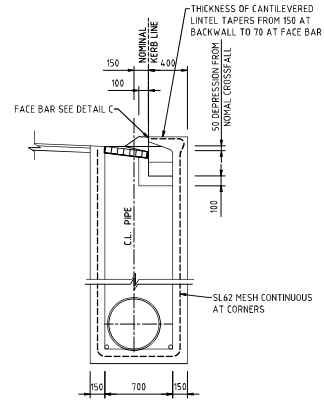

SECTION B-B

0	DRAFT	APR17	RC
ADMT	DESCRIPTION	DATE	AUTH



PO Box 446, Humpy Doo NT 0836
PH 08 8983 0600 FAX: 08 8983 1165

DRAWN
AURECON

STANDARD DRAWING
STANDARD GRATED SIDE ENTRY PIT

SCALE
NOT TO SCALE

DRAWING No.
LC-304

AMDT.
0